



PV Module User Manual & Installation Guide

Applicable Models:

PB-DH96NE-440	PB-DH96TE-460
PB-DH96NE-450	PB-DH96TE-465
PB-DH96NE-460	PB-DH96TE-470
PB-DH96NE.A-440	PB-DH96TE-475
PB-DH96NE.A-445	PB-DH108TD-485
PB-DH96NE.A-450	PB-DH108TD-490
PB-DH96NE.A-455	PB-DH108TD-495
PB-DH96NE.A-460	PB-DH108TD-500
PB-DH108NE.A-500	PB-DH108TD-505
PB-DH108NE.A-505	PB-DH108TD.A-485
PB-DH108NE.A-510	PB-DH108TD.A-490
PB-DH108NE.A-515	PB-DH108TD.A-495
PB-DH132NE-615	PB-DH108TD.A-500
PB-DH132NE-620	PB-DH108TD.A-505
PB-DH132NE-625	PB-DH144TD-650
PB-DH132NE-630	PB-DH144TD-660
PB-DH132NC-705	PB-DH144TD-665
PB-DH132NC-710	PB-DH144TD-670
PB-DH132NC-715	
PB-DH132NC-720	

Table of Contents

1.	INTRODUCTION TO USER MANUAL -----	3
2.	PRECAUTIONARY SAFETY MEASURES-----	4
3.	PRECAUTIONS FOR HANDLING, STORAGE AND TRANSPORT -----	7
4.	UNPACKING MODE -----	14
5.	INTRODUCTION TO INSTALLATION METHOD-----	17
6.	ELECTRICAL INSTALLATION-----	25
7.	MODULE MAINTENANCE -----	31
8.	DIMENSION & PARAMETERS -----	34
9.	DIODE INFORMATION -----	39
10.	RELEASE AND EXECUTION -----	39

1. Introduction to user manual

Thank you for choosing our products! This manual contains relevant information and data in connection with the installation mode and safety operation of the photovoltaic modules (hereinafter referred to as "Module") manufactured by Power Bay Pty Ltd. Power Bay Pty Ltd is hereinafter referred to as "POWERBAY". Failure to comply with these safety instructions may result in injury or property damage.

Before Module installation, installation personnel shall go through and understand these instructions. Should you have any concerns, please contact the service department of POWERBAY or our local representative for further information. Installation personnel shall comply with all safety precautions set out in this manual, local requirements, and regulations of the law and authorized institutions. Prior to installation the solar photovoltaic system, installation personnel shall clearly understand its mechanical and electrical requirements. The operation of the photovoltaic system requires relevant expertise, and therefore the system installation and maintenance shall be performed by qualified personnel with professional skills and knowledge.

Please keep this manual in a secure place, and adopt it as the basis for operation, maintenance and servicing, or use it upon resale or disposal of the Modules. POWERBAY Modules pass the tests of global detection and certification institutions and can be used safely provided that the requirements set out in the provisions of this manual are observed. Any Module installation operator shall notify the above requirements to the end users (or consumers).

The "Module" or "PV Module" mentioned herein refers to one or more single-glass or double-glass series solar modules. Please keep this manual for future reference.

1.1 Disclaimer

POWERBAY reserves the right to revise this manual without prior notice. If the customer fails to comply with the requirements set out in this manual during the installation process of the Module, the limited product warranty offered to the customer will be invalidated. This manual is of no significance to the warranty, whether explicit or implied. This manual doesn't contain any information in relation to any compensation plans for any losses, Module damage or other costs arising from or in relation to the installation, operation, use and maintenance of the Module. POWERBAY disclaims any liability for any infringement on any patent rights or third-party rights arising from the operation or use of the Module.

1.2 Scope of liability

POWERBAY disclaims any liability for any of the following kinds injuries and losses, including but not limited to any physical injuries or property losses resulting from improper Module operation, system installation failure, and violation of the instructions set out in this manual.



Mandatory

Otherwise the product may be damaged or the user's personal safety may be endangered.



Prohibited

Otherwise the product may be damaged or the user's personal safety may be endangered.

2. Precautionary safety measures

2.1 Warning

Please read and understand all safety rules prior to installation, wiring, operation or maintenance of the Module. Photovoltaic Modules may generate power energy when directly exposed to light sources, and a photovoltaic array comprised of multiple Modules may create danger of critical electric shock or burns, thus any person without authorization and related training shall not contact the photovoltaic Module and its wiring terminals, etc.

2.2 General safety

Please read and understand all safety rules prior to installation, wiring, operation or maintenance of the Module. When the Module's battery is directly exposed to sunlight or other light sources, direct current (DC) can be generated, and serious injury may occur when contacting any energized part of the Module, such as wiring terminals, regardless of whether the Module is connected.

When contacting the Module, please make sure to take appropriate protective measures, regardless of whether the photovoltaic Module is connected with the system, e.g.: Insulating tool, safety helmet, insulating gloves, safety belt, and safety insulating boots. When you need to carry out installation, grounding, wiring, cleaning and other operations of the Module, please make sure to use appropriate protective tools for electrical safety. Do not have direct contact with the Module, to avoid electric shock or injury.

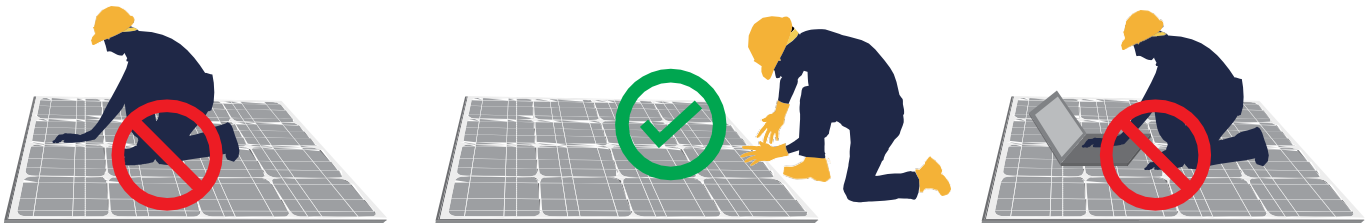

Under general conditions, the open-circuit voltage and short-circuit current values practically generated by the photovoltaic Module may exceed the corresponding values measured under the standard test conditions, thus please comply with the requirements provided in Article 690 of the National Electric Code (NEC) to carry out relevant operations. When determining the rated voltage of the Module, rated current of the conductor, and the specification of the fuse and other controllers connected to the output end of the Module, and if the Module installation doesn't conform to NEC standards, please consider the actual open-circuit voltage and short-circuit current at a safety coefficient of 1.25 to the corresponding values indicated on the nameplate of the Module.

2.3 Conventional safety

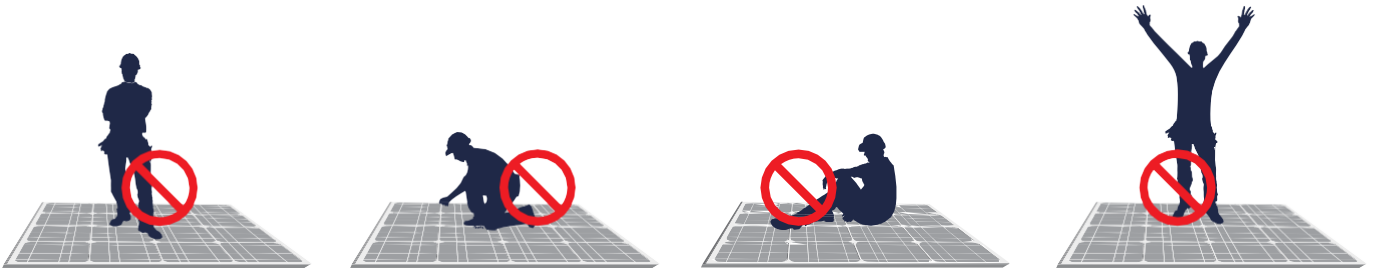

- Do not stand, tread, sit, walk or jump on the Module or Module packing.
- Keep children or unauthorized persons from approaching the installation area or storage area of the Module.
- Do not connect to or disconnect the Module when the Module generates current or external current is with the Module. Do not use water to extinguish fire when power supply is not cut off.
- Do not install the Module in any area of any potentially flammable gases. Do not stack heavy or edgy articles on the Module. Prevent the Module from fall off or any articles from dropping onto or colliding with the Module.
- Do not pull, scratch or bend the output cable with force, otherwise the insulating layer of the cable may be damaged, resulting in power leakage or electric shock. Do not insert any conductive materials into the connector of the Module. The cover of the wiring box shall be closed at all times.
- Do not damage or scratch the front or rear side of the Module to avoid adversely affecting the safety of the Module; if you find any scratch or cutting mark on the front or rear side of the Module, please do not use or install the Module.
- Do not focus sunlight on the Module through mirror or lens. During the normal operating process of the Module, Avoid the Module from being shaded by buildings, trees and chimneys.
- The front glass of the Module plays a protective role to the Module. If the front glass is damaged, the Module may be electrically hazardous (electric shock and fire), and the Module must be replaced immediately because it can't be repaired.
- All installation works must be in complete compliance with local regulations and corresponding domestic or foreign electrical standards.
- All Module systems must be grounded. Please comply with the international standards of IEC and other applicable standards.
- The installation works of the Module array must be performed with the protection of sunlight isolation equipment, and the installation and maintenance of the Module can only be performed by qualified professionals through insulating tools to reduce the risk of power shock.
- If battery is used by the photovoltaic system, please following the instructions of the manufacturer of the battery accessory to the Module, and make sure the battery is validated for the Module.
- It is recommended that professional operators qualified for photovoltaic system installation should be employed for the purpose of Module installation. The operation shall be performed by personnel familiar with corresponding safety procedures, so as to avoid safety hazards.



2.4 Operating safety

- Do not privately repair the Module if the front glass is damaged.
- Do not dismantle the Module or remove any part of the Module.
- Avoid any articles from directly dropping onto or colliding with the Module.
- Do not grab the wiring box or cable to lift the Module in any case.
- Do not use any edgy tool to rub the glass of the Module, otherwise scratches will be left on the Module.
 - Do not install or handle the Module in the installation site under adverse weather conditions such as rain, snow or strong wind.
 - Avoid incorrectly connecting the male and female connectors, check the wiring condition, and make sure all wires and cables are secured with the Module.
 - Do not contact the wiring box or male/female connector with bare hands during the installation process or when the Module is exposed to sunlight.
 - Do not stand or walk on the packing or Module; Avoid one Module from dropping on another Module.

2.5 Fire safety

When installing the Module on roof, please comply with all applicable local fire safety laws and regulations of buildings prior to installation. The roof shall be covered with a layer of fireproof materials with appropriate grades before installation, and make sure that the Module and the installation face are completely ventilated. Different roof structures and installation modes may affect the fireproof performance of the buildings. Incorrect installation mode may cause fire. Use only appropriate Module components pursuant to local regulations, such as fuse, circuit breaker, and grounding connector.

Please do not install or use the Module near open fire or flammable and explosive articles.

3. Precautions for handling, storage and transport

3.1 Turnover precautions

- Please use forklift to unload the Module from the truck (up to two trays of Modules at one time), and place the Module on the level ground.
- Do not stack the Modules in the project site, so as to prevent collision and damage.
- Please use rainproof fabrics to cover the Modules when they are pending for turnover for a long period so as to prevent dampness, and do not unwrap the packing.
- Packaged Modules can be transported through land transportation, sea shipping or air transportation, and make sure the module package is not rolling during transportation.
- Turnover In terms of general transport trucks, up to 2 levels of stacking can be allowed for Module transportation.
- When handling or installing the Module, do not support the Module through its back plate, avoid carrying the Module on the operator's back, and avoid use rope to carry the Module.
- Do not use tricycle to transport the Module. As for transport in the project site, stacking is disallowed.

3.2 Storage precautions

- The Module shall be kept in a dry and ventilated environment, and the recommended storage conditions are as follows: humidity <85%, temperature range -40 ° C-50 ° C, and avoid sunlight exposure and humidity. If the Module is kept in an uncontrollable environment, the storage period shall not exceed 3 months, and additional measures shall be adopted to prevent dampness of connectors and avoid sunlight exposure.
- In any circumstances, please do not stand, climb, walk or jump on the Module. Local heavy load may create micro cracks on the battery, which further undermines the reliability of the Module.
- For long-term storage of the Module, please be advised to store the Module in a standard warehouse through shelves with sufficient bearing capacity and storage space, and patrol inspection shall be conducted on a regular basis to ensure storage safety. If the Module is to be stored in the project site, please avoid the loose ground tending to subside, but choose stable and solid ground or higher ground properly leveled and flattened, so as to ensure that long-term storage of the Module is secure without subsidence and tilting. Once any tilting condition is found, please properly provide reinforcement, while personal safety is ensured.
- In rainy days, please use rainproof fabrics to completely cover the Module and tray, and take rainproof and damp-proof measures for the tray and carton; when the weather turns sunny or windy, please timely remove the rainproof fabrics and dry off the outer packing as soon as possible, so as to avoid subsidence due to dampness and deformation.
- Avoid water immersion of the tray, and properly secure the ground water discharge measures beforehand to prevent looseness, subsidence and other unfavorable conditions of the ground due to substantial ponding after rain. Any unauthorized person is prohibited from accessing the Module storage area, and the Modules should be stored on a centralized basis.
- Please protect the packing from damage, and open the packing of the Module as per the recommended unpacking steps. Please be cautious during unpacking, transportation and storage of the Module. Keep the Module away from edgy articles, especially avoid scratch of the back plate of the Module, as scratch may directly affect the safety of the Module.

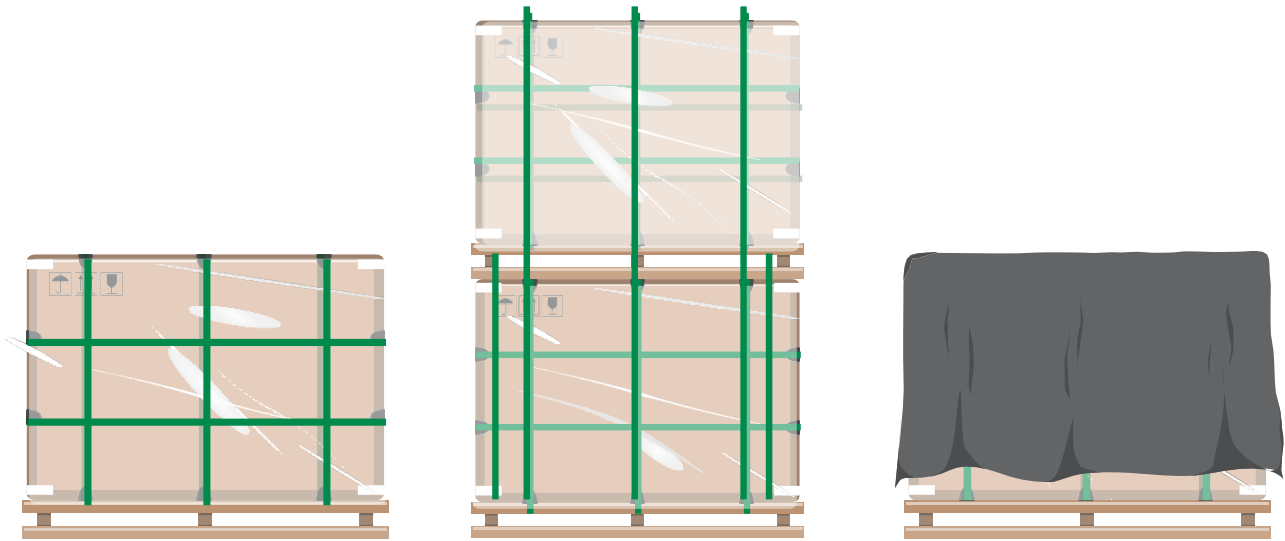

3.3 Unloading mode and precautions

• In any circumstances, short-edge packing shall be not stacked for more than 2 levels, and please reserve sufficient safety distance during forklift operation, and avoid any persons from approaching or passing by from any side. During unloading, please pay attention to the forklift speed, and prevent injury of any persons due to possible Module tilting upon steering.

• The operation ground shall be able to ensure that the packing case is steadily placed and tilting is avoided.

• Upon arrival of the Module, please promptly inspect whether the outer packing case is intact, and verify whether the Module model and quantity indicated on the outer packing case is identical with the delivery note, and immediately contact the logistical personnel and POWERBAY's sales personnel in case that any abnormality is found.

The packing construction is as follows:

Outer box with timber support (model 60/66)

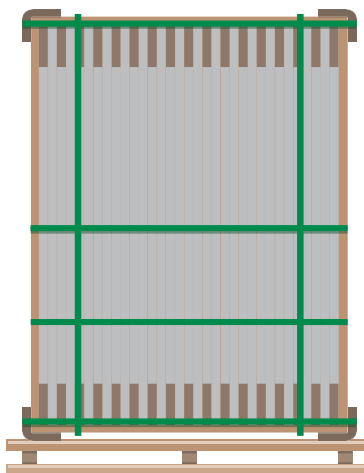

Inner packing

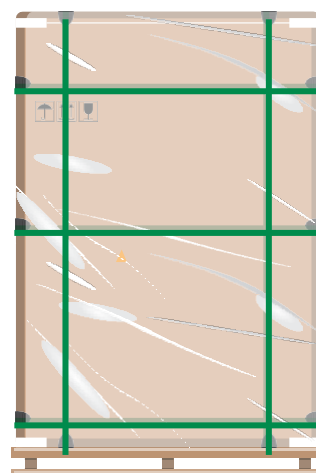

Outer packing

Outer box with timber support (model 48/54/60/66/72/78)

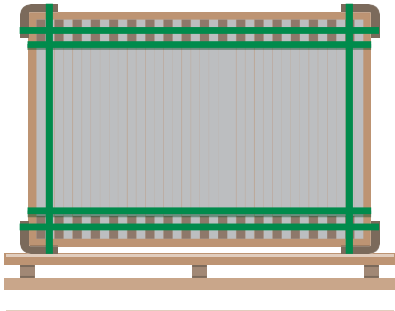

Inner packing

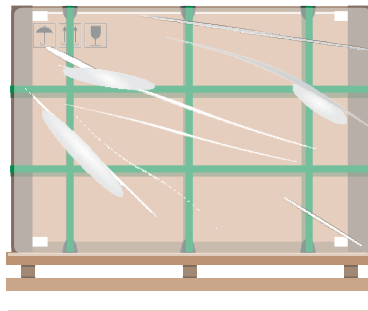

Outer packing

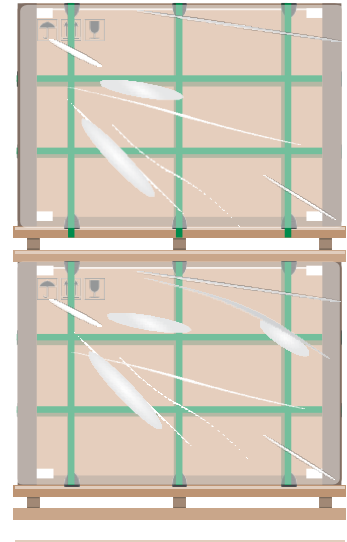

Stacking tray

Outer box without wooden support (model 48/54/60/66/72/78)

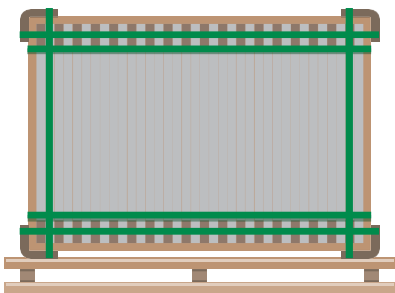

Inner packing

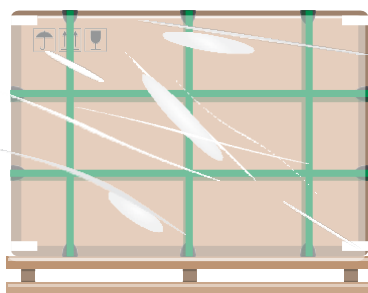

Outer packing

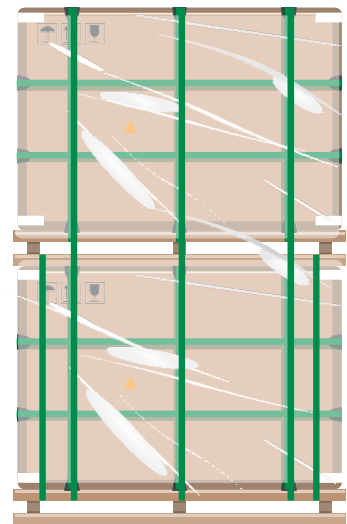

Stacking tray

Hoisting and handling:

When unloading with hoist, please use specialized tooling, and adopt hoisting tools with sufficient tension according to the weight and size of the Module. During hoisting, please timely adjust the sling and keep the Module's gravity center steady. Please use a wooden board on the top of the packing case (its width shall be the same with the wooden board) or other fastening devices to prevent the sling from crushing the packing case and damaging the Module. Please operate the hoist in a steady rate, and when the hoist is approaching the ground, carefully stabilize and position the carton to a relatively level position.

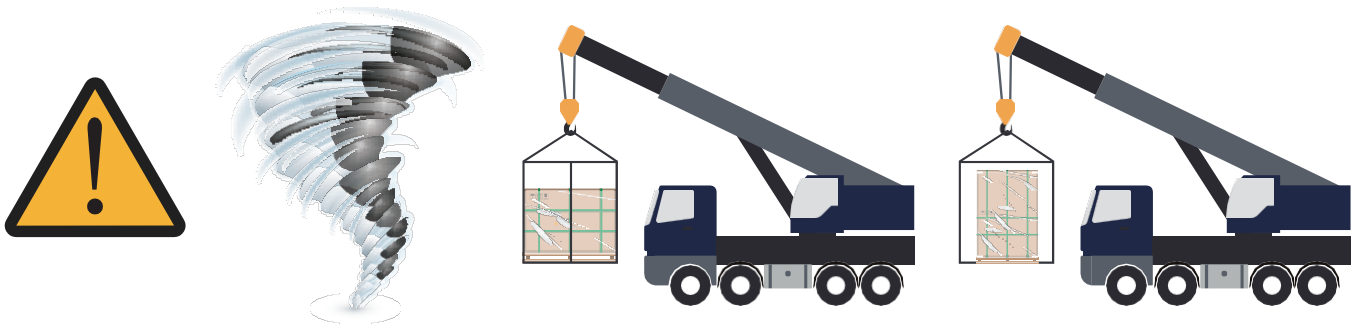

Please do not hoist the photovoltaic Module in any adverse weather conditions, such as strong wind greater than scale 6 (Beaufort scale), heavy snow or heavy rain. Up to 2 trays of modules are allowed for hoisting, in case of horizontal packing. Up to 1 trays of modules are allowed for hoisting, in case of vertical packing.

Hoisting and handling:

The height of the handling platform shall be on the same level with the carriage to the greatest extent, and the driving speed of the forklift shall be controlled within 5km/h upon straight running, and 3km/h upon steering. Emergency stop and start shall be avoided.

If the packing case shields the view of the forklift driver, the driver is advised to operate the forklift in reverse during the handling process, and a specialized person shall be assigned to monitor and provide guidance, so as to prevent collision with any persons or articles and avoid injury accidents or damage of the Module due to drop of the packing case. After transporting the packing case to the installation site, please place it on the level and hardened ground.



General warehousing forklift:

Please use forklift with appropriate lifting capacity, according to the weight of the Module. The depth of the fork sticking into the tray shall not be less than three fourths of the tray length (length of fork not less than $LN3/4$ of tray length). It is advised to extend the height or width of the forklift load-backrest to prevent direct collision of the forklift with Module glass.

In order to ensure better stability of forklift operation, please make sure that the fork spacing shall be adjusted to the largest extent possible while avoiding collision with the two corners of the tray.

Please slowly operate the forklift, and do not crush the carton or tray. Please provide protective buffering materials beforehand (for the section highlighted in yellow in the figure, please use silicone, rubber, EPE or similar materials) to prevent damage of the Module inside the packing case due to external force.



3.4 Project site transport

Project site transport refers to loading and transport of the tray-based Modules between from the storage site to the project site after the Modules arrive at the storage site.

Forklift specification requirement: Please uniformly use forklifts with the rated lifting capacity of N3.5t for loading and transfer of the Modules, and avoid direct contact of the fork protrusion with the cartons or Modules so as to prevent damage of the Modules due to collision

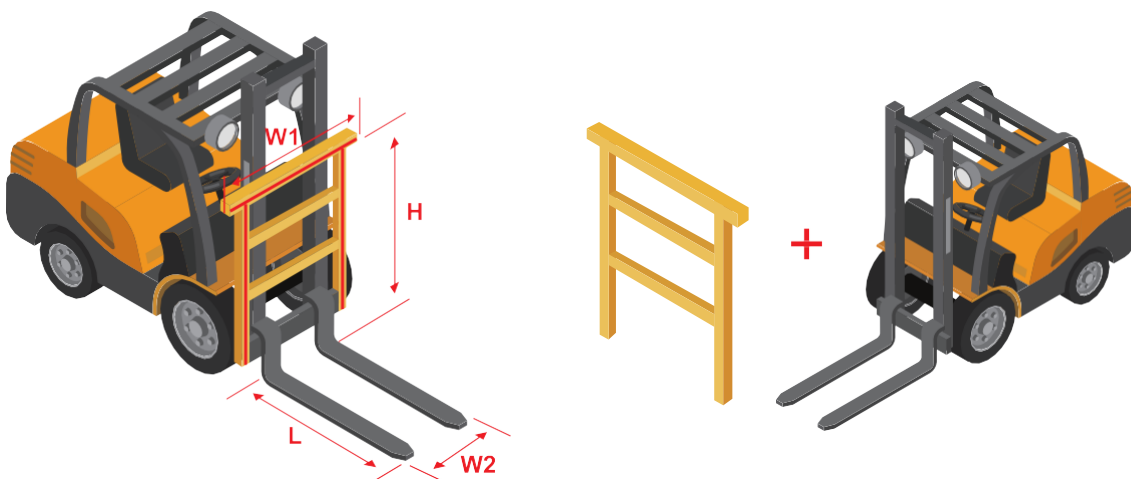

Fork length (L) shall be N1.0m, and fork interval (W2) shall be adjusted to approach the two corners of the tray to the greatest extent.

Gantry height (H) shall be N1.5m or gantry width (W1) shall be N2.5m.

The gantry shall be vertical to the fork, and the gantry structure shall be sturdy (able to bear the load of N1.5t).

When the entire tray of Module is leaned on the gantry, the gantry shall not be deformed due to stress.

The injunction part of the top beam of gantry and the Module packing shall be protected with buffering materials (silicone, rubber, or EPE), to avoid damage of the Module and profiles.

The specification and operating specification of forklift include but not limited to the above information.

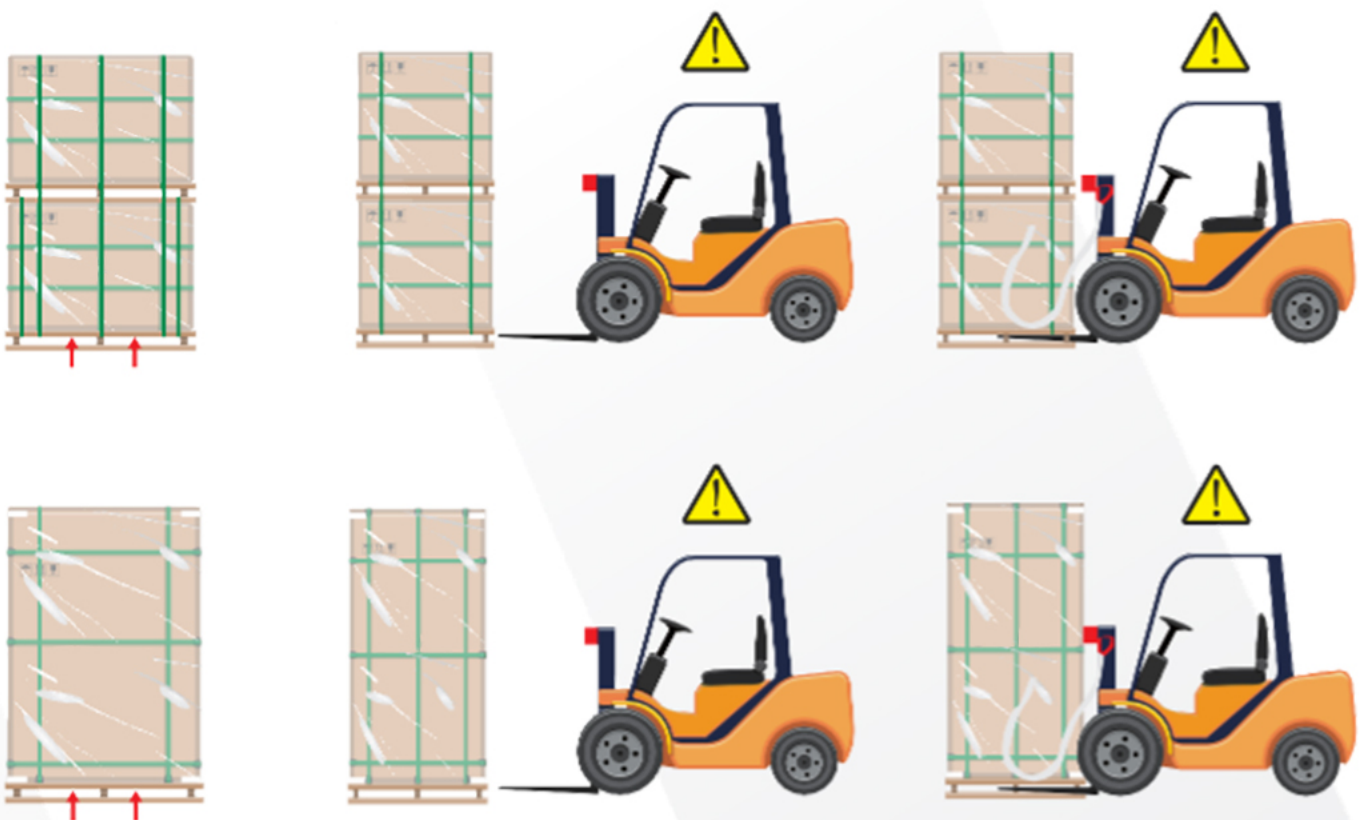

The driver shall operate the fork to slowly stick into the space baseplate and the panel from the long edge side of the tray, and avoid colliding with the Module, and make sure that both sides of the fork gantry are approaching simultaneously. When transporting the module with the forklift, lean the packing case onto the fork gantry, and make sure to fasten the Module with safety ropes featuring the tensile strength of N2000kgf. Upon loading with the forklift, first steadily place the packing case on the ground, then remove the safety ropes when the tilting risk is negligible. Control the driving speed of the forklift during transport, and slowly withdraw the fork when unloading, so as to prevent tilting.

3.5 Secondary transport

Packaged Modules can be transported through land transportation, sea shipping or air transportation. During the transport: Please securely fix the packing case onto the transport platform, and make sure it will not be tilting or shifting.

If unpacked Modules must be transported to another project site, please be advised to combine the separate modules according to the pre-unpacking number of Modules per tray, and wrap them with inner packing straps (recommended for the tensile force of 2100N). Finally, secure the combined Modules with their outer packing cases, and further secure the packing cases (Modules) with the tray through packing straps. Please refer to the pre-packing specification for the number of packing straps.

If one tray is too large for the Modules, please refer to the below figure (left) to center the Modules on the tray (place the Modules on the right side as shown in the below figure (right) in case of distribution packing), and secure the Modules with packing straps (recommended tensile force 2100N) Finally, secure the combined Modules with their outer packing cases, and further secure the packing cases (Modules) with the tray through packing straps. Please refer to the pre-packing specification for the number of packing straps. The tray if not fully covered by Modules shall not be placed on the lower level.

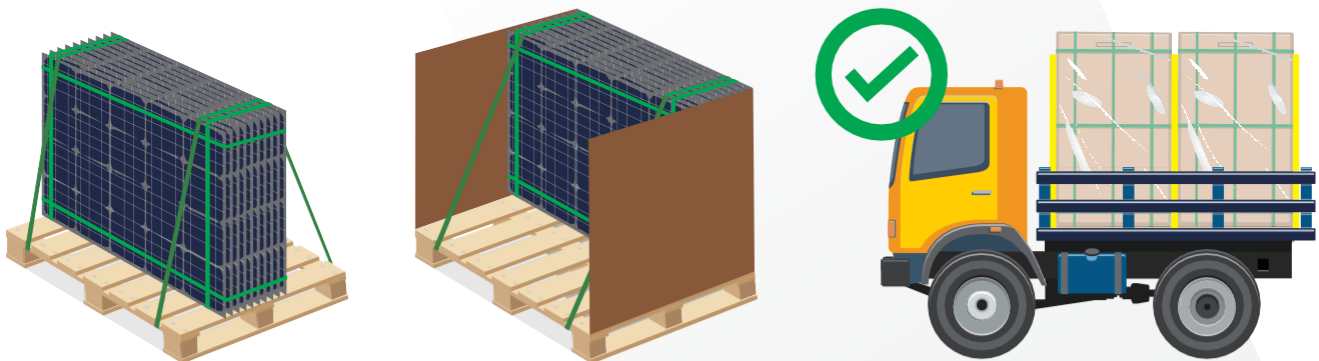

Please use appropriate means of transportation to transport the Modules, and do not use tricycles to transport or handle the Modules, and do not carry out secondary transport of single-glass Modules horizontally packed.

When transported through small truck, the horizontal packing can't be allowed for stacking, and the Module must be fixed onto the trunk with safety ropes on the four sides, and the contact part between the safety rope and the carton must be isolated with corrugated paper or other buffering material. During the transport, the driving speed must be controlled according to road conditions.

When transporting the Module through a van truck or non-van truck, different trays must be stuffed to leave no space, and any empty space at the rear of the van must be stuffed and reinforced to prevent the Module's movement to the rear during transport. When transporting the Modules through a non-van truck, each tray of Modules must be fixed onto the transport vehicle with safety ropes.

The tray must be placed within the loading area of the transport vehicle.

4. Unpacking mode

First place the packing on the level, dry and flattened ground, then successively remove the wrapping film, packing strap, upper cover, and carton. If you need to stack the Modules, please place the tray on the level ground, and the Modules must keep stacked on the tray; Number of Modules ≤ 10 pcs, stacking time ≤ 4 days. The space between two Modules must be stuffed with isolating material, and the height of the isolating material must be 15mm higher than the top of the Module (wiring box). Without the isolating material, horizontal stacking is not recommended.

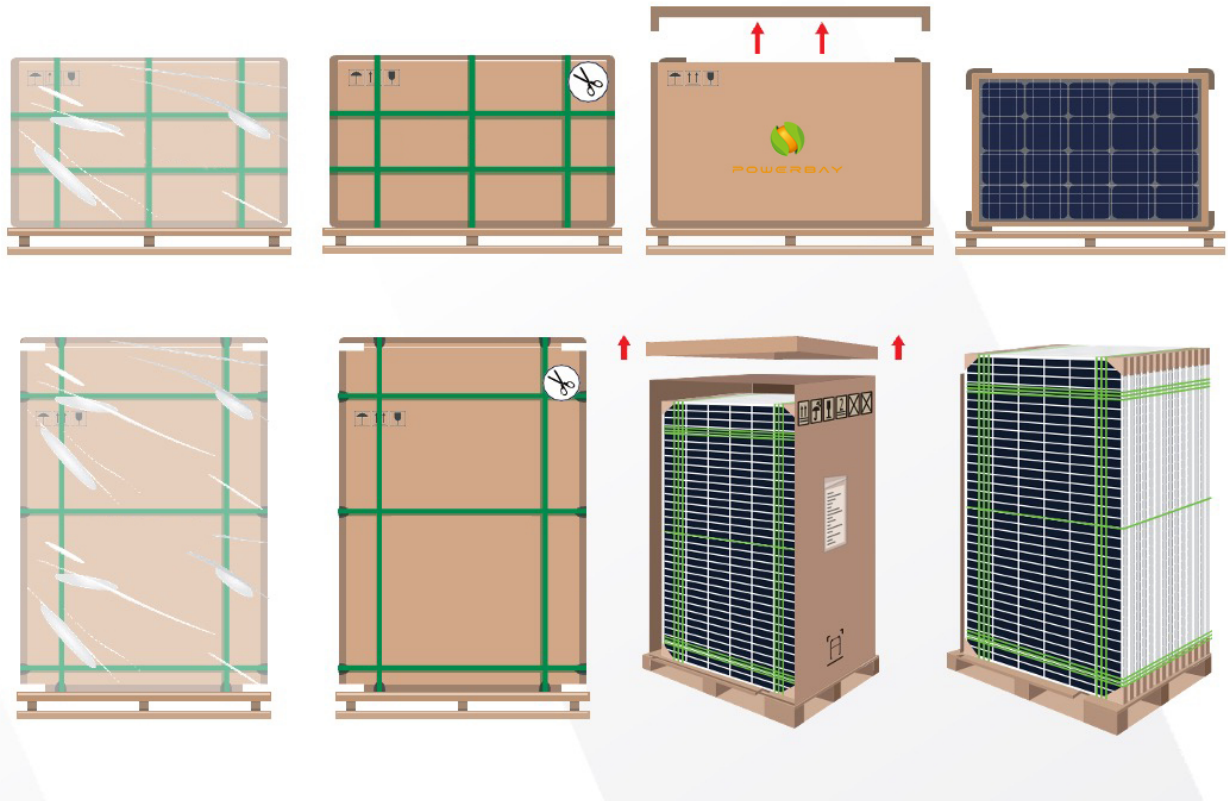

4.1 Enclosed unpacking

- Prior to unpacking, please verify and confirm the intactness of the outer packing, and you are advised to remove the packing strap and wrapping film through a utility knife. Do not remove the packing materials with force, so as to avoid damage to the Modules inside.

- After unpacking, please verify whether the number of Modules in the packing case and the barcode information on the frame are the same with the shipping mark information.

- Please secure the Modules in a reliably supported or fixed environment, and open the packing of the Modules according to the recommended unpacking procedure.

- Based on different product models, the packing mode may be slightly varied. The precautions of unpacking are as follows.

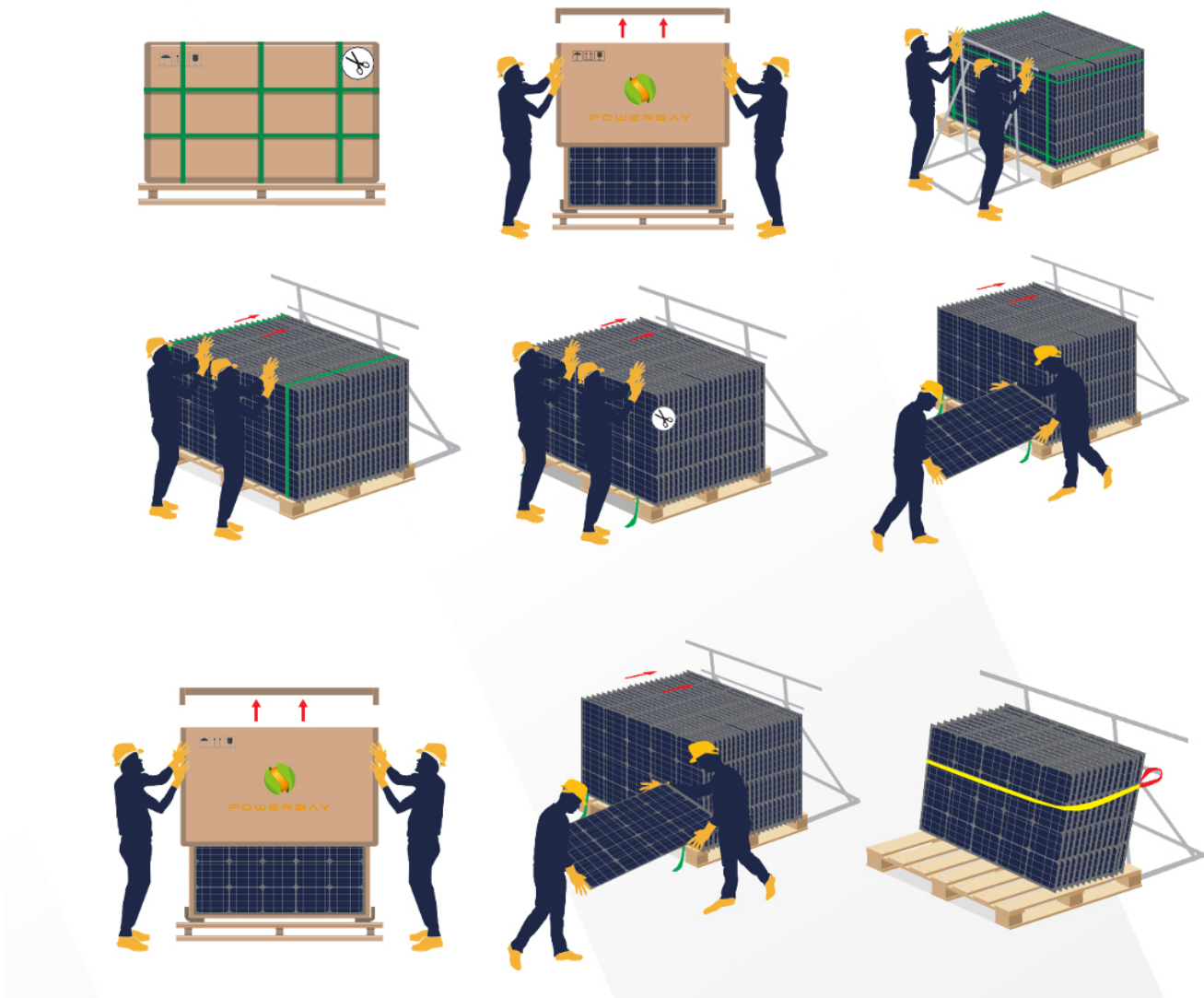

- Upon unpacking, unpacking must be carried out by at least two persons. Operators shall wear protective insulating gloves when handling the Modules to avoid injury and prevent leaving finger-prints on the glass surface.
- If the Modules are not completely withdrawn after unpacking, then the remaining Modules shall be placed horizontally for further repacking, so as to prevent tilting (upon repacking, the glass face of the lower level of Modules shall be upwards, the glass face of the top level of Modules shall be upwards, and the others downwards). The maximum number of Modules if stacked shall not exceed 16 pcs.
- If the Modules after unpacking are not subject to immediate installation (due to adverse weather conditions such as strong wind below scale 6, and provided that the number of Modules is less than 12pcs), then safety ropes shall be used to secure the vertical Modules and the leaning posts with protective measures. (As shown in the figure)

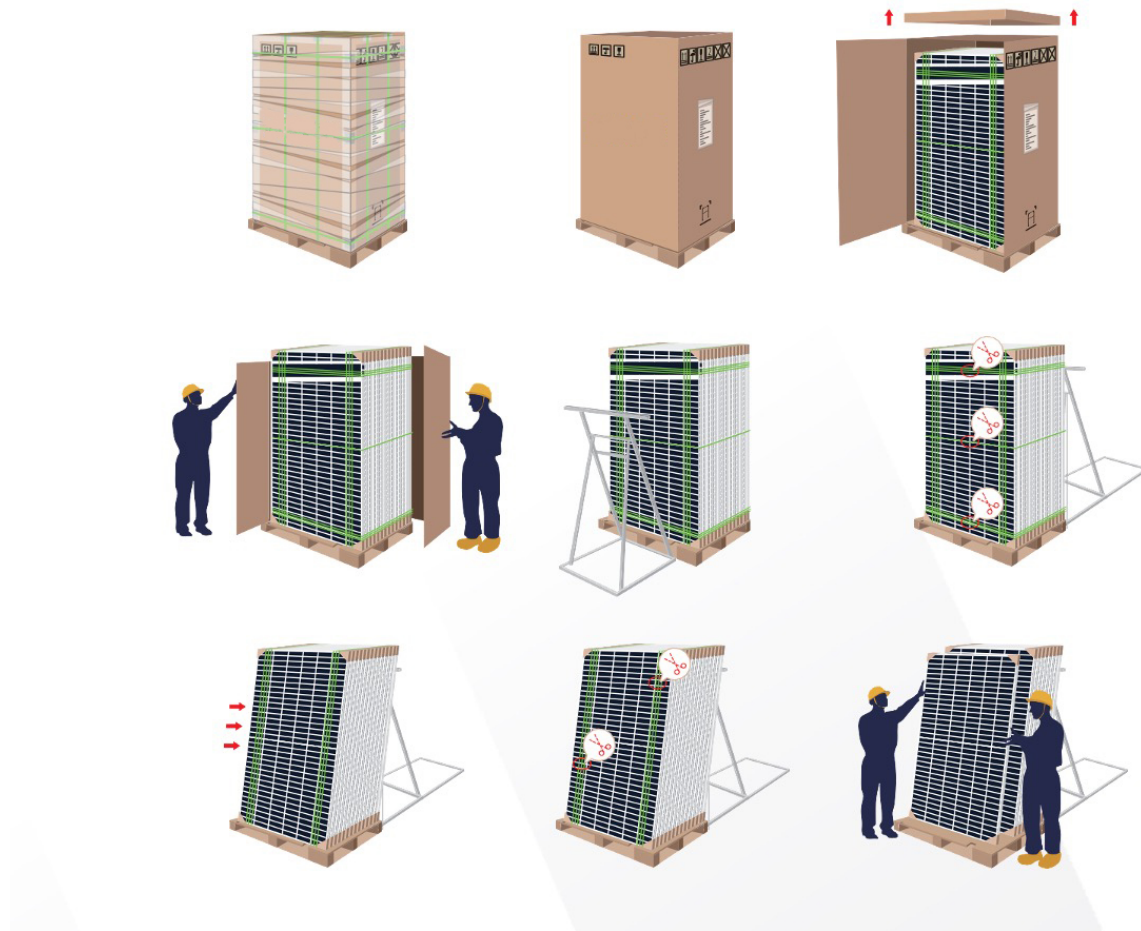

- In windy weather conditions, please do not handle the Modules, and properly secure and fix any unpacked Modules.
- Do not move the leaning posts during the unpacking process, so as to prevent tilting of the Modules.
- Do not carry out outdoor unpacking operations in harsh weather conditions such as rain and snow.
- Prior to removing the inner packing straps, please carry out proper protection to prevent tilting of the whole unit of Modules.
- The operation ground shall be able to ensure that the packing case is steadily placed and tilting is avoided.
- Do not lean the Module on the installation post. Do not use wooden strips or other items to directly contact and support the rear side of the Module.
- Do not handle the Module by a single operator, so as to avoid scratches, deformation or cracks of the Module due to sliding and collision of the Module with other Modules. When lifting the Module, do not pull the wiring box or cables to withdraw the Module.
- Please carry out the operation in strict accordance with the requirements of unpacking instructions. When removing the packing straps of horizontal packing, please provide protective measures to avoid scratching your face or eyes, and avoid standing on the tray during unpacking, but handle the Modules from the two sides of the tray.

5. Introduction to installation method

5.1 Introduction to installation environment

POWERBAY recommends that the Modules shall be installed in the working environment with the temperature of -40°C to 70°C which is the monthly average highest and lowest temperature of the installation places. Maximum module operating temperature (T98): 70°C. The recommended backside reflectivity should be within 20%. Please provide protective measures in sandstorm, prevent sands from entering the Modules, otherwise the installation and performance may be affected.

Generally, the Module shall be installed in a location which receives the most solar radiation in a whole year. In the northern hemisphere, the Module shall be installed to the south, and to the north if in the southern hemisphere. If Module's tilting angle deviates from due south (or due north) by 30 degrees, the power output will be 10% to 15% less, and 20% to 30% less if 60 degrees. When choosing the ideal location, please avoid trees, buildings and other obstacles which may shade the Module. Although we have installed appropriate bypass diodes to minimize the loss, shade will always reduce the output power. Carry out lightning protection for modules installed in places with frequent lightning and thunder. Do not install modules in places with possible flammable gases. Modules cannot be used in environments with excessive hail, snows, flue gas, air pollution and soot or in places with strong corrosive substances such as salt, salt mist, saline, active chemical steam, acid rain, or other substances corroding modules, which may affect module safety or performance. Please take protective measures to ensure reliable and safe installation of modules in severe environments such as heavy snow, cold and strong wind or islands close to water and salt mist or deserts.

When the photovoltaic generation system is used with battery, please install the battery in strict accordance with relevant laws and regulations. In doing so, the operation of the system can be protected, and the user's safe use can be assured. Please observe the recommendations of the battery manufacturer in relation to installation, operation and maintenance of the battery. Generally speaking, the battery shall be kept away from main traffic routes of people and animals.

While ensuring normal operation of the battery, please avoid sunlight exposure and rain & snow erosion, and keep good ventilation; Most batteries generate hydrogen while in charging, which can be explosive easily, thus please do not create any open fire or spark in the surrounding environment of the battery; If the battery is installed outdoors, please make sure to place it in a specially designed location and keep good insulation and ventilation.

When the Modules are to be stacked on the roof, please first verify the bearing capacity of the roof, and prepare a construction plan conforming to applicable specification requirements. When the Module is used in an area with high wind pressure and high snow pressure, please provide a structural design of supporting and Clamp according to the local design specification, and ensure that the external load doesn't exceed the mechanical strength of the Module.

Additional Note: Altitude \leq 2000 meters “Artificially concentrated sunlight producing current above values stated on label shall not be directed onto front and back side of module.”

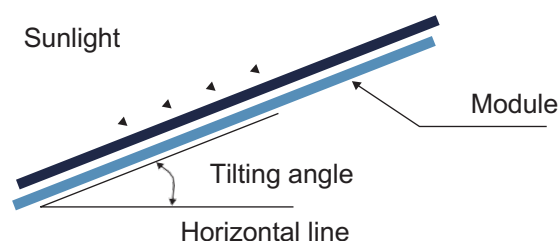

5.2 Module tilting angle

The tilting angle of photovoltaic Modules refers to the included angle between the photovoltaic Module and the level ground. Different tilting angles can be adopted for different projects due to varied local conditions. POWERBAY recommends that the tilting angle of the Module shall not be less than 10° . For your ideal choice of tilting angle, please refer to the design procedures, specifications, regulations or follow the recommendations of the Module installation provider.

In terms of ideal installation, the Module shall face south for installation in the northern hemisphere, and face north in the southern hemisphere. If the photovoltaic Module is installed in North America or other regions where UL standard applies, then, according to local laws and regulations, a clearance of 155mm (recommended value) shall be reserved between the Module (backboard surface) and the wall or roof surface. If other installation specification is adopted, the UL certification or fire resistance grade of the photovoltaic Module may be affected.

The Module can be installed by the following methods: Bolt installation and Clamp installation. The installation of the Module shall be in strict accordance with the operation instructions provided in this manual so as to conform to IEC certification. Prior to Module installation, please go through these instructions to get familiar with the entire installation procedures.

The connection between the Module and the bracket system can be made through the mounting holes of the frame, Clamp, or snap-in system. Module installation must be in line with the installation requirements. If the Module is to be installed in a way inconsistent with the instructions declared by POWERBAY, please consult the local technical support or after-sales personnel of POWERBAY and obtain the consent of POWERBAY, otherwise, the Module may be damaged and the product warranty will be invalidated.

The term "load" mentioned in this manual refers to test load. For the installation method conforming to local laws and regulations, the safety coefficient of 1.5 shall be adopted when estimating the allowable maximum design load. The project design load is dependent on structure, application standard, installation location, and local climate condition. The design load shall be determined by professional supplier or professional engineer. For details, please comply with local architectural regulations or contact professional architectural engineer.

The described Module shall be installed on an extended continuous bracket underneath the Module. If the Module is to be installed without a continuous bracket, the maximum allowable load of the Module will decrease, which shall be reviewed by POWERBAY.

The minimum spacing between two Modules is 10mm. If special brackets are used, you may determine an appropriate interval according to the technical requirements of the bracket supplier.

Note: All installation methods introduced herein are for reference only. POWERBAY is not responsible for providing relevant installation parts, and the design and installation of the Module system. The mechanical load and safety must be verified by a professional system installation provider or qualified persons with corresponding experience. It is prohibited to soak the connector in water, including seawater and fresh water, after the module is installed.



Prior to installation, please make the following major verifications:

- Please check whether the appearance is defective, whether there are any sundries, and verify the safety performance of the wiring box. If any sundries, please remove them.

- Check whether the serial number of the Module is correct.
- The front side of the POWERBAY Modules can bear a maximum stress of 5400Pa (only limited to the Module models described in this manual), and 2400Pa for the rear side. The maximum design stress bearable by the front side is 3600Pa, and 1600Pa for the rear side. The safety coefficient is 1.5. If the installation environment of the Module is snowy and windy, please adopt particular protective measures for the installation so as to meet actual requirements.

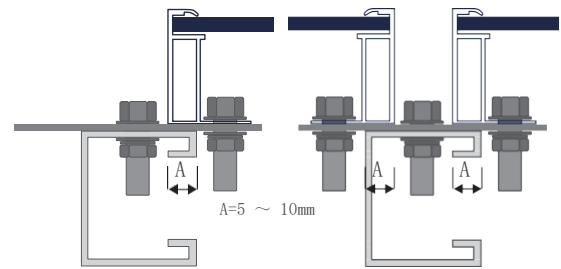
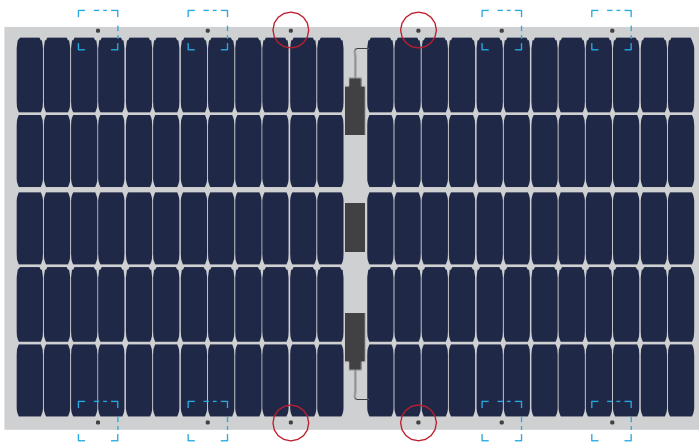
5.3 Bolt installation



-  There are 6~8 mounting holes for M8 bolts
-  There are 4 mounting holes for M6 bolts

Installation requirements		Bolt installation						
		beam vertical to the long frame					beam parallel to the long frame	
Module model	frame high (mm)	Outer quad hole		Inner quad hole			Outer quad hole	
		(1400mm)	(1600mm)	(990mm)	(1100mm)	(1200mm)	(1400mm)	(1600mm)
PB-DH96NE	30	+2400, -2400	/	+5400, -2400	/	/	+2400, -2400	/
PB-DH96NE.A								
PB-DH96TE								
PB-DH108NE.A								
PB-DH108TD								
PB-DH108TD.A								
PB-DH132NE	33	+5400, -2400	/	/	/	/	+2400, -2400	/
PB-DH144TD								
PB-DH132NC								

Note: "/" indicates not applicable. The loads in the table include safety factors, representing the test loads.

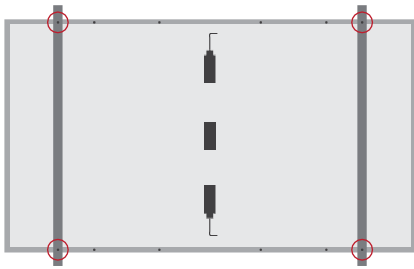

Bolt installation with outer quad holes
(beam vertical to the long frame)

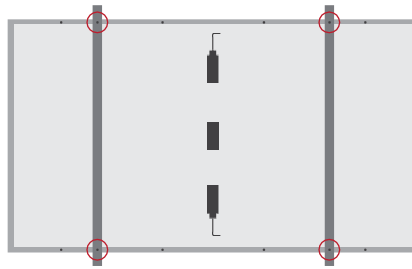

Bolt installation with inner quad holes
(beam vertical to the long frame)

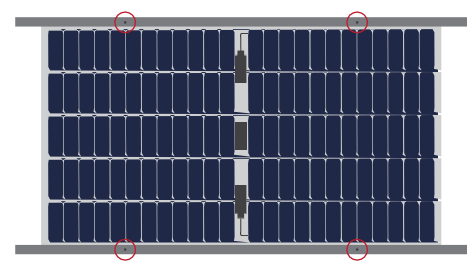

Bolt installation with outer quad holes
(beam parallel to the long frame)

There are 4~6 pairs of 9*14mm mounting holes on the frames of each Module, which can be used to ideally fix the Module to the supporting structure to optimize its load bearing capacity.

In order to extend the lifespan of the installation to the greatest extent, POWERBAY strongly recommends that anti-corrosive (stainless steel) fastenings should be used.

As the standard configuration, POWERBAY Modules have 8 mounting holes for M8 bolts (as shown in the dashed box in blue color, which are hereinafter referred to as inner quad holes and outer quad holes respectively). In case of Model 72/78 Modules, they are additionally provided with 4 mounting holes for M6 bolts, suitable for tracking brackets from vendors such as Next tracker. Through the mounting holes on the back-side frames of the Module, bolts can be used to fix the Module onto the bracket.

M8/M6 bolts, flat gaskets, spring washers and nuts are used at each fastening position to fix the Module, and tightened to the torque of 16N·m-20N·m/10N·m-14N·m. The yield strength of bolts and nuts shall not be smaller than 450MPa. All parts contacting the frames shall be fixed with flat stainless steel gaskets with the minimum thickness of 1.8mm and the outer diameter of 16mm.

5.4 Clamp installation

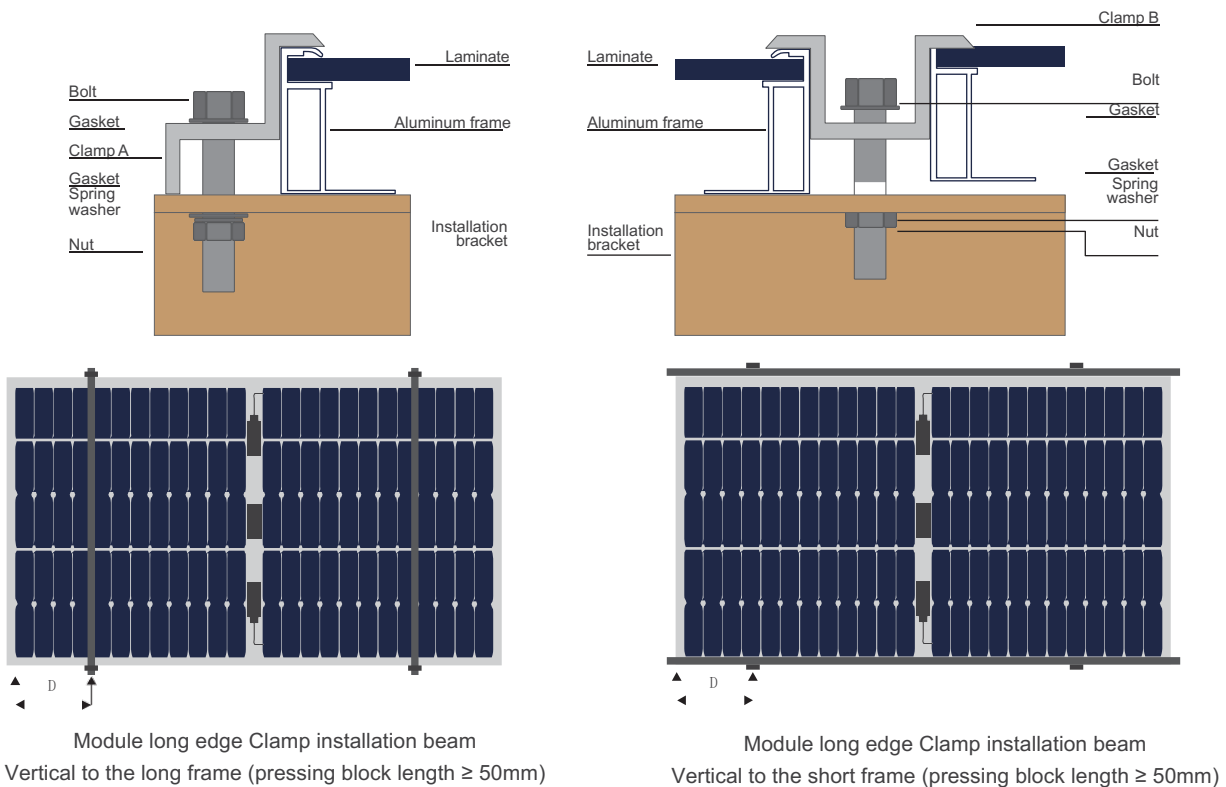

Installation requirements		Clamp installation		
		$350 \leq D \leq 450$	$460 \leq D \leq 560$	$250 \leq D \leq 300$
Module model	frame high (mm)	Beam vertical to the long frame	beam vertical to the long frame	beam vertical to the short frame
PB-DH96NE	30	+ 5400, -2400	/	+ 2400, -2400
PB-DH96NE.A				
PB-DH96TE				
PB-DH108NE.A				
PB-DH108TD				
PB-DH108TD.A				

Note: "/" indicates not applicable. The loads in the table include safety factors, representing the test loads.

Installation requirements		Clamp installation		
		$460 \leq D \leq 560$	$480 \leq D \leq 560$	$495 \leq D \leq 615$
Module model	frame high (mm)	beam vertical to the long frame		
PB-DH132NE	30	+ 5400, -2400	/	/
PB-DH144TD				
PB-DH132NC	33	/	+ 5400, -2400	/

Note: "/" indicates not applicable. The loads in the table include safety factors, representing the test loads.

- If the pressing block installation method is adopted, please ensure that at least 4 pressing blocks are provided on each Module. Two pressing blocks are installed on each long edge (longitudinal) or each short edge (horizontal) of the Module respectively, and the number of pressing blocks used depends on the pressure intensity of wind and snow in the local environment. If the actual pressure exceeds to the estimation, additional pressing blocks or brackets shall be used to ensure that the Module can bear the pressure.

- POWERBAY has tested the Modules with different Clamps of varied manufacturers and recommends that M8/M6 (full thread preferred) fastenings shall be used in line with local environment. The material and type selection of fastenings shall be dependent on local environment.

- The Clamps shall clamp the Module frames for 10mm-12mm, and the minimum spacing between two modules is 10mm.

- The Module Clamps shall not get into contact with the front-side glass, and shall not deform the frames. Please make sure to avoid the shading effect of the Clamps.

- Module frames can't be adjusted in any case. During installation or use, the drainage holes can't be obstruct-

ed in any case.

- Contact width of the press and frame: $10\text{mm} \leq D < 12\text{mm}$; wall thickness of the press $\geq 4\text{mm}$.
- The torque exerted shall be determined according to the mechanical design standards of the bolts you are using.

Range of torsional moment for M8 bolts: $16\text{N}\cdot\text{m}-20\text{N}\cdot\text{m}$;

Range of torsional moment for M6 bolts: $10\text{N}\cdot\text{m}-14\text{N}\cdot\text{m}$;

Frames modules see below for reference:

Mounting fasteners	Model/specification:		Material
Clamp A	Length ≥ 40		Aluminum alloy 6063
Clamp B	Length ≥ 40		Aluminum alloy 6063
Bolt	M8 (full thread is preferred)	M6 (full thread is preferred)	Q235B/SUS304
Gasket	2 pcs, thickness $\geq 1.5\text{mm}$, and outside diameter 16mm	2 pcs, thickness $\geq 1.5\text{mm}$, and outer diameter 12-18mm	Q235B/SUS304
Spring washer	8	6	Q235B/SUS304
Nut	M8	M6	Q235B/SUS304
Remarks: The material and type selection of fastenings shall be dependent on local environment.			

If other sizes of pressing blocks are required, they shall first go through sufficient verification of POWERBAY.

5.5 Single-Axis installation

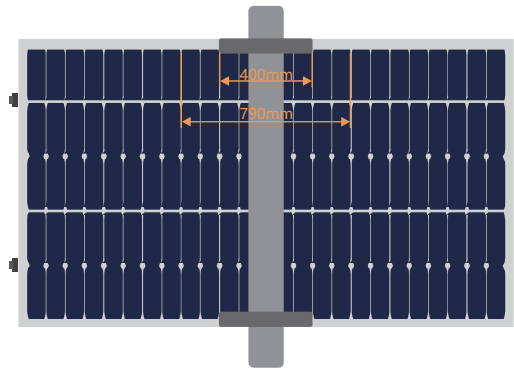

Mounting rails run perpendicular to the long side frame.
Distance between mounting holes is 400 mm/790mm

Installation requirements		Single-Axis installation	
		400mm	790mm
Module model	frame high (mm)	Mounting rails run perpendicular to the long side frame Distance between mounting holes	
PB-DH132NE	30	+ 1200, -1200	+ 1800, -1800
PB-DH144TD	30	+ 1200, -1200	+ 1800, -1800

The bolts used in this section is to secure the module in each fixing location with an M6 bolt, two flat washers, a spring washer and a nut, and tighten them to a torque of 10-14 N.m, it is recommended to take regular inspection of the tightening to meet the torque range.

For all products covered in this section, all parts in contact with the frame should use flat stainless steel washers of minimum 1.5 mm (0.06 inch) thickness with an outer diameter of 16-18 mm (0.63-0.71 inch).

The module has to be installed on the purlins.

5.6 Other mounting options

Guide rails mounted parallel to long side bolts

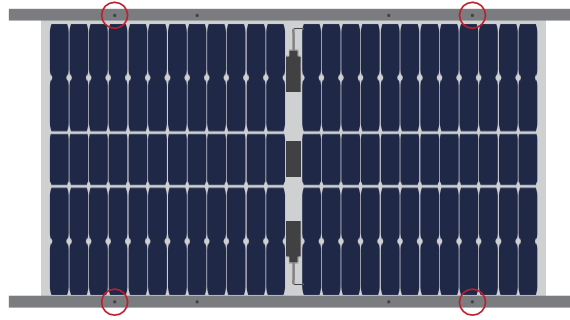

Installation requirements		Guide rails mounted parallel to long side bolts
Module model	frame high (mm)	Distance between mounting holes on the same side 1400mm
PB-DH96NE.A	30	+ 2600, -2400
PB-DH108NE.A		

Shared Beam Fixture Installation

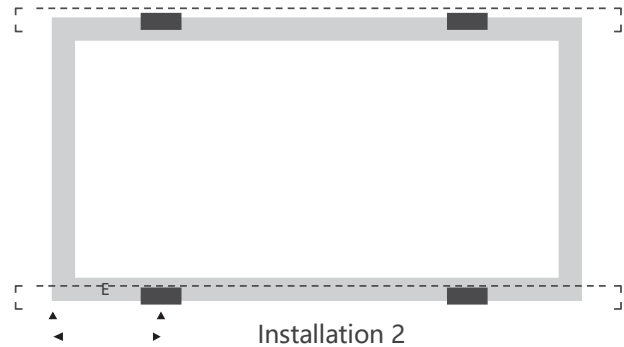

Installation requirements		Shared Beam Fixture Installation	
		Installation 1	Installation 2
Module model	frame high (mm)	L= (40mm-100mm)	L= (350mm-500mm)
PB-DH96NE.A	30	+ 2000, -1800	+ 2400, -2400
PB-DH108NE.A		+ 1800, -1400	+ 2400, -2400

6. Electrical Installation



WARNING Electrical Hazard

This module produces electricity when exposed to light. Follow all applicable electrical safety precautions. Australia Installations should be in accordance with AS/NZS 3000 and AS/NZS 5033. ONLY qualified personnel can install or perform maintenance work on these modules. BE AWARE of dangerous high DC voltage when connecting module. DO NOT damage or scratch the rear surface of the module. DO NOT handle or install module when they are wet. Under normal conditions, a photovoltaic module is likely to experience conditions that produce more current and/or voltage than reported at standard test conditions. Accordingly, the values of ISC and VOC marked on this module should be multiplied by a factor of 1,25 when determining component voltage ratings, conductor current ratings, fuse sizes, and size of controls connected to the PV output.

6.1 General installation

- Any hardware used must be compatible with the mounting structure material to avoid galvanic corrosion
- It is not recommended to use modules with different configurations (grounding, wiring) in the same system.
- The module maximum system voltage is 1500 volts DC. For applications requiring a high operating voltage several modules can be connected in series to form a string of modules; The system voltage is then equal to the sum of the voltage of each module.
- For applications requiring high operating currents several strings of modules can be connected in parallel; the system current is then equal to the sum of the current of each string of modules.
- Our modules are supplied with connectors to be used for system electrical connections.
- The maximum number of series connected modules can be calculated through this formula: $1500 / (1.25 \cdot V_{oc})$. The recommended maximum configuration is one parallel string.

Module Series	Maximum System Voltage	Maximum Number of Modules
Regular Module 144 series	1500V	1

And the number of modules have something to do with system design parameters such as current or power output.

- Please refer to local regulations to determine the system wires size, type and temperature.
- To prevent the cables and the connectors from overheating, the cross section of the cables and the capacity of the connectors must be selected to suit the maximum system short circuit current (The recommended cable cross section is 4mm² for a single module and if rated current of a connector is higher than 10A). Please note that the upper limit temperature of cable is 85°C, and that of the connector is 105°C, the lower limit temperature is -40°C. And all the cables diameter that being used for wiring must reach at least 4 mm². The type of the connectors are: 1.PV-DA01M2-XY / PV-DA02M2-XY, 2.PV-ZH202B 3.PV-KST4-EVO2/xy_UR,PV-KBT4-EVO2/xy_UR, 4.PV-KST4-EVO2A/xy,PV-KBT4-EVO2A/xy, 5.PV-JK03M2/xy (Plug+Socket) The type of the cables are 1.62930 IEC 131 1*4.0mm²/1*6.0mm².
- The DC current generated by photovoltaic systems can be converted into AC and fed into a public grid. As local utilities' policies on connecting renewable energy systems to their grids vary from region to region. A qualified system designer or integrator should always be consulted. Building permits, inspections and approvals by the local utility are generally required.

6.2 Wiring requirements

• The electrical performance parameters of the Module are derived from tests under standard test conditions, that is, solar radiation intensity 1000W/m², AM1.5 and ambient temperature 25°C. Under certain circumstances, the Module may generate a voltage or current value which is higher or lower than the rated value. When determining the rated voltage of other parts of the photovoltaic system, rated conductor current, fuse specification, and specification of control elements connected to the Module output, please apply the safety coefficient of 1.25 to the short-circuit current voltage values indicated on the Module.

• The string voltage must not be higher than the maximum system voltage, as well as the maximum input voltage of the inverter and the other electrical devices installed in the system in order to ensure this, the open circuit voltage of an array needs to be calculated at the lowest expected local ambient temperature, which can be determined using the following formula.

$$\text{Max System Voltage} \geq N \times \text{Voc} \times [1 + \text{TCvoc} \times (\text{Tmin} - 25)]$$

where

N	Number of modules in series
Voc	Open circuit voltage (refer to product label or data sheet)
TCvoc	Temperature coefficient of open circuit voltage (refer to datasheet)
Tmin	The minimum ambient temperature

• All wiring works must be performed by qualified installation personnel according to local regulations and procedures. Ensure the connectors are fastened and correctly connected without external pressure. The connectors may be only used for circuit connection, instead of circuit on/off.

• The connectors shall be kept dry and clean, and protected from rain and dampness. Make sure to avoid sunlight exposure to and water immersion of the connectors.

• Before connected in place, the connectors are not resistant to water at all, therefore the connectors shall be connected in place as soon as possible or provided with waterproof measures upon Module installation, so as to avoid exposure of the connections to moisture and dust.

• In case of serial connection, please proceed with the Modules with the same level of current, and the voltage generated by Modules connected in series shall not be higher than the maximum voltage allowable by the system, and the number of Modules connected in series is dependent on system design, inverter type and environment condition.

• The maximum rated fuse current value of each group of Modules connected in series is indicated on the product label and the specification & parameter sheet. The rated fuse current corresponds to the reverse current value bearable by the Module. Please select appropriate fuses based on the maximum fuse current and local electrical performance installation requirements, so as to protect the Modules connected in series and in parallel in the circuit.

• If a group of Module is connected to another group through opposite polarity, irreparable damage will be made to the Modules. Prior to parallel connection, please make sure to measure and verify the voltage and polarity of each group of Modules. If the measurement result shows that the polarity between different groups is reverse or the voltage difference is greater than 10V, then please check the structural configuration prior to connection.

- POWERBAY Modules adopt specialized ultraviolet-proof photovoltaic cables with the cross-sectional area greater than or equal to 4mm^2 . All other cables connected to the DC system shall be with similar (or higher) specification. POWERBAY recommends that all cables shall be laid in appropriate pipes or troughs and kept away from any place that is prone to ponding. Voltage of series connection shall not be higher than the maximum voltage bearable by the system and the maximum input voltage of the inverters and other electrical devices installed in the system. In order to ensure safety mentioned above, the open-circuit voltage of the Module arrays shall be estimated under the minimum ambient temperature expected in the installation location.

- The outer diameter range of cables is 5-7mm.

- In terms of onsite wiring, please use specialized photovoltaic cables with temperature resistance of minimum 90°C , light fastness, and cross-sectional area not lower than 4mm^2 as the photovoltaic connection cable. If the Modules are to be laid on the roof, $4\text{-}6\text{mm}^2$ photovoltaic specialized cables are preferred. The requirement of the minimum bending radius of the cables is 43mm .

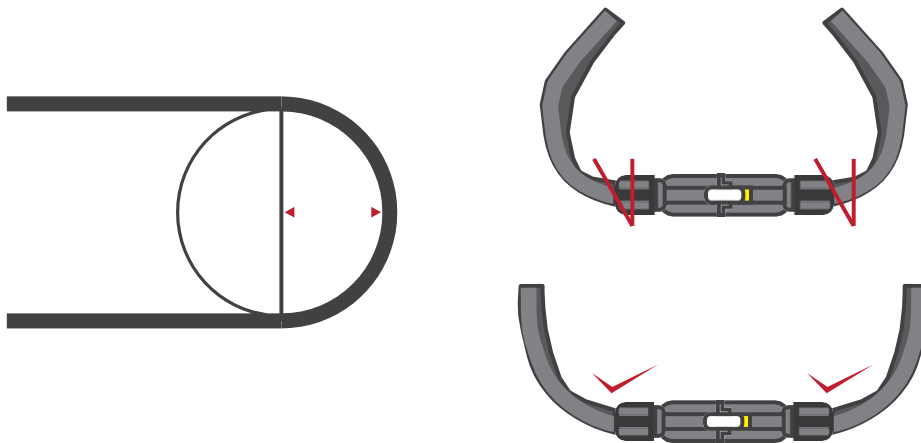

6.3 Wiring method

Recommended wiring method for triple wiring box (vertical: Standard cable length (Note: Cable extension required for the single-row terminal)).

Vertical installation of Modules:
Select the standard stub cable

Stub cable natural connection method type C

Note: Serial connection for the terminals of upper and lower rows

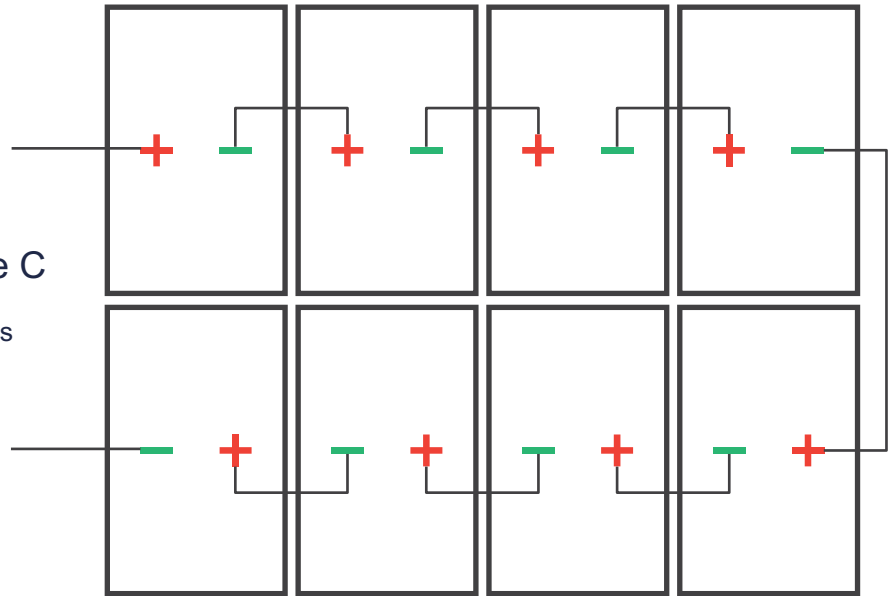

Vertical installation of Modules:
Select the standard stub cable

Stub cable natural connection method type -

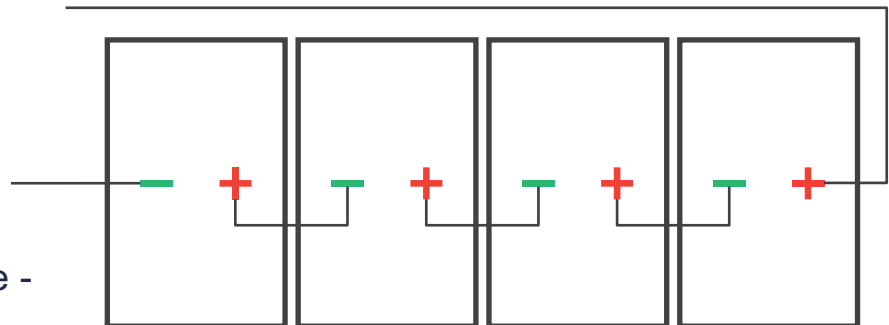

Horizontal installation of Modules:
Select the standard long cable or customized cable

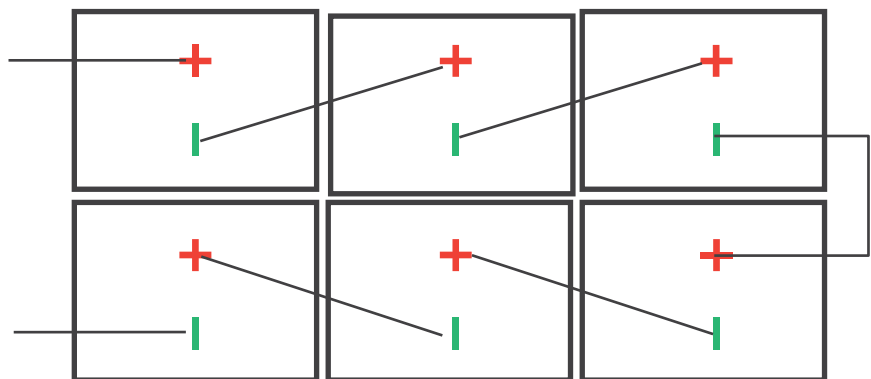

6.4 Grounding connection

Modules must be grounded (Modules have been certified with the safety grade II), and make sure that the grounding method complies with the local electrical instructions and regulations. Qualified electrical personnel shall be engaged to perform the grounding connection operation.

In terms of the design of the Modules, anodized anti-corrosive aluminum alloy frames are adopted as rigid supports. In order to ensure use safety and avoid the Modules from damaged by lightning and static electricity, the frames of the Modules must be grounded. Upon grounding, the grounding device must be sufficiently contacted with the inside of the aluminum alloy frames and penetrating the oxidized film on the frame surface. Do not make any additional grounding holes on the frames of the Modules. The grounding conductor or lead can be any materials used as electrical conductors as required by the National Electrical Code, such as copper and copper alloy. The grounding conductor shall be connected to the ground through appropriate grounding electrodes. The holes indicated with the grounding signs on the frames can only be used for grounding rather than Module installation. Frame- less double-glass Modules are not required for grounding since they do not have bare conductors.

- For grounding and connection requirements, please refer to local and national safety and electrical standards. If requested, please use the recommended connector type for the ground connection.
- The correct grounding by proper grounding wires and components of the border and all metal parts are connected together, the grounding conductor or conduction band may be copper, copper alloy or other as their national electrical code to accept the material, then the grounding conductor must use the grounding electrode is connected to the ground right.
- The installation of the components in the middle part can be connected to the grounding of the metal frame by means of a third party registered grounding device.
- In design of modules, the anodized corrosion resistant aluminum alloy frame is used for rigidity support. For safety utilization and to protect modules from lightning and static-electricity damage, the module frame shall be grounded.
- The grounding device shall be in full contact with inner side of the aluminum alloy and penetrate the frame surface oxide film.
- Do not drill additional grounding holes on module frame.
- To get the optimal power output, POWERBAY suggests that DC negative pole of the module array shall be grounded in installation of modules. Otherwise, the system power output will be reduced.
- Module installation methods can not lead to electrochemical corrosion between module aluminum frame and different metals.
- Holes on the frame shall be drilled in advance and grounding signs shall be indicated. These holes are only used for grounding but not for installation of modules.

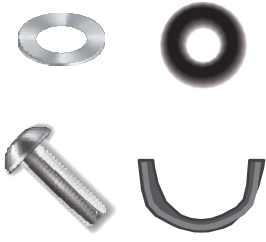
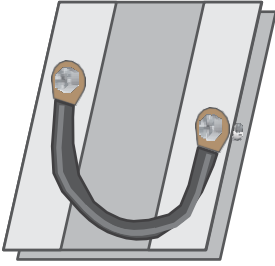
Parts	Schematic diagram	Connection mode
		<p>Arrange the star washer, flat washer and grounding lead successively, and thread the screw into the grounding hole, and fasten the screw to fix the adjacent Module.</p>

We recommend that the following method should be adopted for correct grounding, as shown in Figure 3.

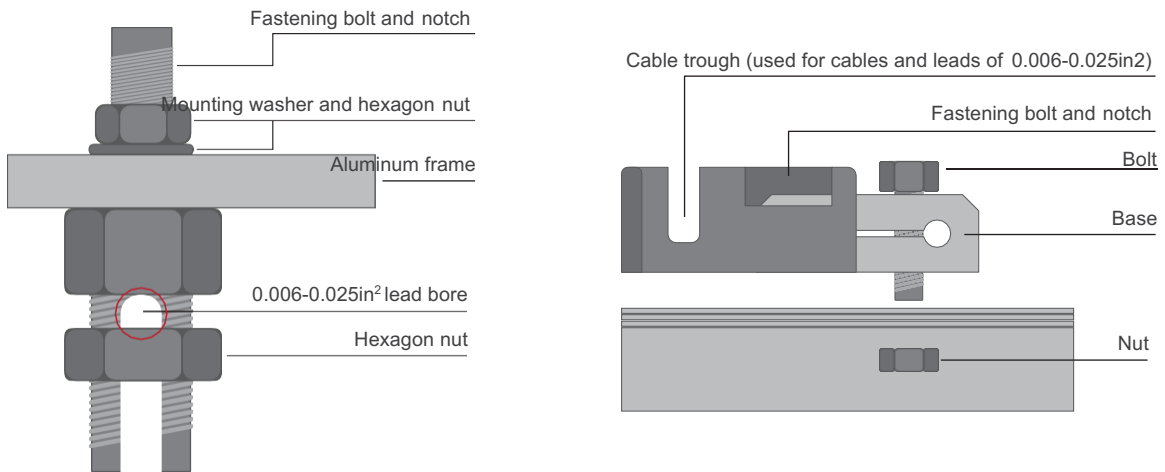

Figure 3 Photovoltaic Module Grounding Method (applicable to IEC)

Below is the recommended grounding method:

Grounding with the grounding clamp

There is a grounding hole $\text{Ø}4.2\text{mm}$ in the middle (near the edge) of the back-side frame of the Module. The midline of the grounding mark and the midline of the hole are coincided, and consistent with the frame length and orientation.

The grounding between different Modules must be verified and validated by qualified electricians, and the grounding device shall be manufactured by a qualified electrical manufacturer. The recommended torsional moment value is $2.3\text{N}\cdot\text{m}$. The grounding clamp shall use 12AWG copper wires. Avoid stress and damage the copper wires during installation. Use unoccupied mounting holes for grounding. Mounting holes not used on the Module can be used to install the grounding device.

- Align the grounding clamp with the mounting hole on the frame. Thread the grounding bolt through the grounding clamp and frame.

- Place the toothed washer on one side and screw on the lock nut.

- Thread the grounding lead through the grounding clamp. The material and size of the grounding lead shall meet relevant national, regional or international laws, regulations and standards.

- Screw on the fastening bolt of grounding lead and complete the installation.

Other third-party grounding device: POWERBAY Module can be grounded through third-party ground devices, provided that the grounding is proved to be reliable and the grounding device is installed according to the requirements of the manufacturer.

7. Module maintenance

The module must be inspected and maintained on a regular basis, especially within the warranty period. In order to ensure that the Module can reach its optimal performance, the following maintenance measures shall be adopted preferably:

7.1 Appearance inspection

- It is recommended that a preventive check shall be performed every 6 months, and the elements of the Module shall not be replaced without authorization. Where it is required to carry out inspection or maintenance for electrical performance or mechanical performance, professional personnel are preferably engaged to carry out the inspection or maintenance, so as to avoid electric shock or casualties.

- As a protective part used in transport, the frame protection guard is not subject to appearance control, and the customer may determine to remove or retain it at sole discretion.

- Check whether the glass of the Module is damaged.

- Check whether any edgy object has contacted the Module surface.

- Check whether the Module is shaded by any obstacles and foreign matters.

- Check whether the wiring terminal of the Module is detached, etc.

- Check whether the Module surface is cracked due to artificial causes.

- Check whether the fastening bolts between the Module and the bracket are loosened or damaged and carry out reinforcement or maintenance in a timely manner.

7.2 Connector and cable inspection

All wirings shall be performed by qualified installation personnel according to the local electrical construction procedures, specifications, manuals and regulations.

A preventive inspection shall be performed every 6 months preferably, and all wires and cables shall be inspected and verified as to whether their connection is secure. Avoid sunlight exposure to the cables and keep them from ponding areas. Keep the dryness and cleanness of the connectors, and verify whether the screw caps of the connectors are tightened. Please do not connect the connectors if they are damp, filthy or otherwise contaminated.

Please check whether the sealing glue of the wiring box is cracked, and identify any sign of aging of the Module. The checks include any damage caused by rodents, aging due to weather condition, and whether all connectors are securely connected and free of corrosion. Check whether the Modules are soundly grounded, and ensure that the contacts are clean, dry and free of corrosion at all times.

Preferably, the tensional torque and wiring condition of all terminals and bolts shall be inspected on a yearly basis. In addition, please check whether the installed hardware is fastened securely. Any looseness of connection may cause electric arcs and electric shocks that can be damaging the Module arrays.

7.3 Requirements of cleaning

Dust accumulation and contamination (e.g. industrial wastewater, bird droppings) on the glass surface of the Modules may reduce the power output, and may even result in local hot spots. The extent of impact depends on the transparency of the contaminants. Minor dust accumulation or contamination on the glass may affect the sunlight intensity and uniformity, but the hazard is negligible, as it normally will not significantly reduce the power output.

When the module is operating, please avoid any environmental influential factors which shade the Module in part or in whole, e.g.: Other Modules, Module system brackets, bird stay, substantial dusts, dirt, or plants. All these obstacles will reduce the power output significantly. POWERBAY recommends that, the Module surface shall not be shaded at any time when solar radiation is available. Dust accumulation on the Module's glass surface will reduce the power output, thus regular cleaning is preferred.

In order to reduce potential electric shock or burning, POWERBAY recommends that the cleaning work of photo-voltaic Modules shall be preferably performed when the solar radiation is weak (e.g. in early morning or at dusk), especially in areas with high temperature.

The cleaning frequency depends on the rate of dirt accumulation in the installation site. Under normal circumstances, rainwater can play the role of Module surface cleaning, which reduces the cleaning frequency. POWERBAY recommends that a moist sponge or a soft cloth shall be used to wrap the glass surface. Do not use cleansers containing alkaline or acid to clean the Modules. Do not use any rough materials to clean the Modules in any case.

The rear side of the Module is not subject to cleaning, however, if it is necessary to clean the rear side, please avoid using any edgy objects that may cause damage or penetrate the base materials.

Do not attempt to clean a photovoltaic Module with broken glass or bare wires, otherwise you may be exposed to the risk of electric shock.

7.4 Cleaning method

Method A: High-pressure water cleaning

- Water quality requirement; PH: 5~7;
- Chloride or salinity content: 0-3,000mg/L
- Turbidity: 0-30NTU
- Electrical conductivity: 1500~3000 μ s/cm
- Total dissolved solid: \leq 1000mg/L
- Water hardness 0-40mg/L
- Non-alkaline water shall be used. When conditions allow, the cleaning shall be performed with high pressure softened water (the recommended maximum water pressure is 4MPa [40bar]).



Water



Anhydrous ethanol



Dust-free gloves



Dust-free paper

Method B: Compressed air cleaning

For cleaning the soft filths on the Module (e.g. Dust), pneumatic cleaning is recommended. It can be applied as long as the actual cleaning performance is sound.

Method C: Moist wipe cleaning

In case of substantial filths on the Module surface, please use an insulating brush, sponge or other soft cleaning tools to carry out cleaning gently. Ensure that any brush or stirring tool used for cleaning is made of insulating materials to minimize the risk of electric shock, and that the cleaning tools will not create any scratches on the glass or aluminum alloy frames. If any oil stains, please cautiously use an eco-friendly cleanser.

Method D: Cleaning robot

If a cleaning robot is used to carry out dry cleaning, the material of the cleaning brush shall be soft plastic, and the cleaning process and post-cleaning effect shall not cause any scratches on the Module glass surface and aluminum alloy frames, and the weight of the cleaning robot shall be moderate. Any damage or power deterioration of the Module due to poor cleaning performed by the cleaning robot shall not be covered by the warranty provided by POWERBAY.

7.5 Post-cleaning Module inspection

Visual inspection of the Module shall indicate that the appearance is clean, tidy, and without dirt. Through sampling inspection, the Module surface shall be free of dust accumulation and without any evident scratches and cracks caused artificially.

Check whether the post-cleaning Module bracket is tilting or bent, etc., and whether the Module's wiring terminal is detached, etc. After cleaning of the photovoltaic Module, make sure to maintain the cleaning records.

If the Module malfunctions after installation, please immediately notify the installation provider.

8. Dimension & Parameters

PB-DH96NE-XXX Model Series (XXX=440,450,460) Electrical Characteristics

STC: front side irradiance 1000 W/m², 25 °C, AM 1.5:

Rated Power (Pmp)	440	450	460
Power Tolerance There is ±3% uncertainty at Max Power at STC.	±3%	±3%	±3%
Maximum Power Voltage (Vmp)	29.65	30.02	30.41
Maximum Power Current (Imp)	14.84	14.99	15.13
Open Circuit Voltage (Voc) ±3%	34.92	35.30	35.68
Short Circuit Current (Isc) ±5%	15.94	16.08	16.22

Working Conditions		Mechanical Specifications	
Pmax Temperature Coefficient	-0.28%/°C	External Dimensions	1762*1134*30mm
Voc Temperature Coefficient	-0.25 %/°C	Weight	21kg/21.6kg
Isc Temperature Coefficient	+0.045%/°C	Solar Cells	Monocrystalline 182x105mm(96pcs) 182.2x105mm(96pcs) 182.3x105mm(96pcs)
Nominal Module Operating Temperature (NMOT)	42±2 °C	Front glass	1.6mm tempered glass, low iron
Maximum System Voltage	1500V	Frame	Anodized/Electrophoretic aluminum alloy
Maximum Series Fuse	30A	Junction Box	IP68
Grounding conductivity	<0.1Ω	Output Cables	4.0 mm ²
Safety Class	Class II	Hailstone Impact Test	80 km/h for 25mm ice ball
Insulation Resistance	≥100MΩ		

PB-DH96NE.A-XXX (XXX=440,445,450,455,460) Electrical Characteristics

STC: front side irradiance 1000 W/m², 25 °C, AM 1.5:

Rated Power (Pmp)	440	445	450	455	460
Power Tolerance There is ±3% uncertainty at Max Power at STC.	±3%	±3%	±3%	±3%	±3%
Maximum Power Voltage (Vmp)	29.65	29.83	30.02	30.22	30.41
Maximum Power Current (Imp)	14.84	14.92	14.99	15.06	15.13
Open Circuit Voltage (Voc) ±3%	34.92	35.11	35.30	35.50	35.68
Short Circuit Current (Isc) ±5%	15.94	16.01	16.08	16.16	16.22

Working Conditions		Mechanical Specifications	
Pmax Temperature Coefficient	-0.28%/°C	External Dimensions	1762*1134*30mm
Voc Temperature Coefficient	-0.25 %/°C	Weight	21.6kg
Isc Temperature Coefficient	+0.045%/°C	Solar Cells	Monocrystalline 182.3x105mm(96pcs)
Nominal Module Operating Temperature (NMOT)	42±2 °C	Front glass	1.6mm tempered glass, low iron
Maximum System Voltage	1500V	Frame	Anodized/Electrophoretic aluminum alloy
Maximum Series Fuse	30A	Junction Box	IP68
Grounding Conductivity	<0.1Ω	Output Cables	4.0 mm ²
Safety Class	Class II	Hailstone Impact Test	80 km/h for 25mm ice ball
Insulation Resistance	≥100MΩ		

PB-DH108NE.A-XXX (XXX=500,505,510,515) Electrical Characteristics

 STC: front side irradiance 1000 W/m², 25 °C, AM 1.5:

Rated Power (Pmp)	500	505	510	515
Power Tolerance There is ±3% uncertainty at Max Power at STC.	±3%	±3%	±3%	±3%
Maximum Power Voltage (Vmp)	33.50	33.67	33.87	34.07
Maximum Power Current (Imp)	14.93	15.00	15.06	15.12
Open Circuit Voltage (Voc) ±3%	39.70	39.88	40.08	40.26
Short Circuit Current (Isc) ±5%	16.05	16.11	16.17	16.22

Working Conditions		Mechanical Specifications	
Pmax Temperature Coefficient	-0.28%/°C	External Dimensions	1960×1134×30mm 1961×1134×30mm
Voc Temperature Coefficient	-0.25 %/°C	Weight	27.1kg
Isc Temperature Coefficient	+0.045%/°C	Solar Cells	Monocrystalline 182x105mm(108pcs) 182.2x105mm(108pcs) 182.3x105mm(108pcs)
Nominal Module Operating Temperature (NMOT)	42±2 °C	Front glass	2.0mm tempered glass, low iron
Maximum System Voltage	1500V	Frame	Anodized/Electrophoretic aluminum alloy
Maximum Series Fuse	30A	Junction Box	IP68
Grounding conductivity	<0.1Ω	Output Cables	4.0 mm ²
Safety Class	Class II	Hailstone Impact Test	80 km/h for 25mm ice ball
Insulation Resistance	≥100MΩ		

PB-DH132NE-XXX Model Series (XXX=615, 620, 625, 630) Electrical Characteristics

 STC: front side irradiance 1000 W/m², 25 °C, AM 1.5:

Rated Power (Pmp)	615	620	625	630
Power Tolerance There is ±3% uncertainty at Max Power at STC.	±3%	±3%	±3%	±3%
Maximum Power Voltage (Vmp)	40.31	40.48	40.64	40.81
Maximum Power Current (Imp)	15.26	15.32	15.38	15.44
Open Circuit Voltage (Voc) ±3%	48.18	48.35	48.51	48.69
Short Circuit Current (Isc) ±5%	16.06	16.12	16.18	16.24

Working Conditions		Mechanical Specifications	
Pmax Temperature Coefficient	-0.28%/°C	External Dimensions	2382*1134*30mm
Voc Temperature Coefficient	-0.25 %/°C	Weight	32.5kg/31.9kg
Isc Temperature Coefficient	+0.045%/°C	Solar Cells	Monocrystalline 182x105mm(132pcs) 182.2x105mm(132pc) 182.3x105mm(132pcs)
Nominal Module Operating Temperature (NMOT)	42±2 °C	Front glass	2.0mm tempered glass, low iron
Maximum System Voltage	1500V	Frame	Anodized/Electrophoretic aluminum alloy
Maximum Series Fuse	30A	Junction Box	IP68
Grounding conductivity	<0.1Ω	Output Cables	4.0 mm2
Safety Class	Class II	Hailstone Impact Test	80 km/h for 25mm ice ball
Insulation Resistance	≥100MΩ		

PB-DH132NC-XXX (XXX=705, 710,715,720) Electrical Characteristics

 STC: front side irradiance 1000 W/m², 25 °C, AM 1.5:

Rated Power (Pmp)	705	710	715	720
Power Tolerance There is ±3% uncertainty at Max Power at STC.	±3%	±3%	±3%	±3%
Maximum Power Voltage (Vmp)	40.62	40.81	40.98	41.15
Maximum Power Current (Imp)	17.36	17.40	17.45	17.50
Open Circuit Voltage (Voc) ±3%	48.72	48.92	49.08	49.24
Short Circuit Current (Isc) ±5%	18.38	18.42	18.47	18.52

Working Conditions		Mechanical Specifications	
Pmax Temperature Coefficient	-0.28%/°C	External Dimensions	2384*1303*33mm
Voc Temperature Coefficient	-0.25 %/°C	Weight	37.1kg
Isc Temperature Coefficient	+0.045%/°C	Solar Cells	Monocrystalline 210x105mm(132pcs)
Nominal Module Operating Temperature (NMOT)	42±2 °C	Front glass	2.0mm tempered glass, low iron
Maximum System Voltage	1500V	Frame	Anodized/Electrophoretic aluminum alloy
Maximum Series Fuse	35A	Junction Box	IP68
Grounding conductivity	<0.1Ω	Output Cables	4.0 mm2
Safety Class	Class II	Hailstone Impact Test	80 km/h for 25mm ice ball
Insulation Resistance	≥100MΩ		

PB-DH96TE (XXX=460, 465,470,475) Electrical Characteristics

 STC: front side irradiance 1000 W/m², 25 °C, AM 1.5:

Rated Power (Pmp)	460	465	470	475
Power Tolerance There is ±3% uncertainty at Max Power at STC.	±3%	±3%	±3%	±3%
Maximum Power Voltage (Vmp)	29.80	29.97	30.14	30.30
Maximum Power Current (Imp)	15.44	15.52	15.60	15.68
Open Circuit Voltage (Voc) ±3%	35.62	35.79	35.96	36.13
Short Circuit Current (Isc) ±5%	16.40	16.48	16.56	16.64

Working Conditions		Mechanical Specifications	
Pmax Temperature Coefficient	-0.26%/°C	External Dimensions	1762*1134*30mm
Voc Temperature Coefficient	-0.22 %/°C	Weight	21.6kg
Isc Temperature Coefficient	+0.050%/°C	Solar Cells	Monocrystalline 182.3x105mm(96pcs)
Nominal Module Operating Temperature (NMOT)	42±2 °C	Front glass	1.6mm tempered glass, low iron
Maximum System Voltage	1500V	Frame	Anodized/Electrophoretic aluminum alloy
Maximum Series Fuse	30A	Junction Box	IP68
Grounding Conductivity	<0.1Ω	Output Cables	4.0 mm ²
Safety Class	Class II	Hailstone Impact Test	80 km/h for 25mm ice ball
Insulation Resistance	≥100MΩ		

PB-DH108TD-XXX (XXX=485,490,495,500,505) Electrical Characteristics

 STC: front side irradiance 1000 W/m², 25 °C, AM 1.5:

Rated Power (Pmp)	485	490	495	500	505
Power Tolerance There is ±3% uncertainty at Max Power at STC.	±3%	±3%	±3%	±3%	±3%
Maximum Power Voltage (Vmp)	33.64	33.75	33.86	33.97	34.08
Maximum Power Current (Imp)	14.42	14.52	14.62	14.72	14.82
Open Circuit Voltage (Voc) ±3%	40.45	40.56	40.66	40.77	40.88
Short Circuit Current (Isc) ±5%	15.18	15.28	15.38	15.48	15.58

Working Conditions		Mechanical Specifications	
Pmax Temperature Coefficient	-0.26%/°C	External Dimensions	1800*1134*30mm
Voc Temperature Coefficient	-0.22 %/°C	Weight	21.7kg
Isc Temperature Coefficient	+0.050%/°C	Solar Cells	Monocrystalline 183x98.65mm(108pcs)
Nominal Module Operating Temperature (NMOT)	42±2 °C	Front glass	1.6mm tempered glass, low iron or 2.0mm?
Maximum System Voltage	1500V	Frame	Anodized/Electrophoretic aluminum alloy
Maximum Series Fuse	30A	Junction Box	IP68
Grounding conductivity	<0.1Ω	Output Cables	4.0 mm ²
Safety Class	Class II	Hailstone Impact Test	80 km/h for 25mm ice ball
Insulation Resistance	≥100MΩ		

PB-DH108TD.A-XXX (XXX=485,490,495,500,505) Electrical Characteristics

 STC: front side irradiance 1000 W/m², 25 °C, AM 1.5:

Rated Power (Pmp)	485	490	495	500	505
Power Tolerance There is ±3% uncertainty at Max Power at STC.	±3%	±3%	±3%	±3%	±3%
Maximum Power Voltage (Vmp)	33.64	33.75	33.86	33.97	34.08
Maximum Power Current (Imp)	14.42	14.52	14.62	14.72	14.82
Open Circuit Voltage (Voc) ±3%	40.45	40.56	40.66	40.77	40.88
Short Circuit Current (Isc) ±5%	15.18	15.28	15.38	15.48	15.58

Working Conditions		Mechanical Specifications	
Pmax Temperature Coefficient	-0.26%/°C	External Dimensions	1800*1134*30mm
Voc Temperature Coefficient	-0.22 %/°C	Weight	21.7kg
Isc Temperature Coefficient	+0.050%/°C	Solar Cells	Monocrystalline 183x98.65mm(108pcs)
Nominal Module Operating Temperature (NMOT)	42±2 °C	Front glass	1.6mm tempered glass, low iron or 2.0mm?
Maximum System Voltage	1500V	Frame	Anodized/Electrophoretic aluminum alloy
Maximum Series Fuse	30A	Junction Box	IP68
Grounding conductivity	<0.1Ω	Output Cables	4.0 mm2
Safety Class	Class II	Hailstone Impact Test	80 km/h for 25mm ice ball
Insulation Resistance	≥100MΩ		

PB-DH144TD-XXX (XXX=650,660,665,670) Electrical Characteristics

 STC: front side irradiance 1000 W/m², 25 °C, AM 1.5:

Rated Power (Pmp)	650	660	665	670	650
Power Tolerance There is ±3% uncertainty at Max Power at STC.	±3%	±3%	±3%	±3%	±3%
Maximum Power Voltage (Vmp)	44.99	45.19	45.28	45.38	44.99
Maximum Power Current (Imp)	14.45	14.61	14.69	14.77	14.45
Open Circuit Voltage (Voc) ±3%	54.00	54.20	54.30	54.40	54.00
Short Circuit Current (Isc) ±5%	15.22	15.38	15.46	15.54	15.22

Working Conditions		Mechanical Specifications	
Pmax Temperature Coefficient	-0.26%/°C	External Dimensions	2382*1134*30mm
Voc Temperature Coefficient	-0.22 %/°C	Weight	31.9kg
Isc Temperature Coefficient	+0.050%/°C	Solar Cells	Monocrystalline 183x98.65mm(144pcs)
Nominal Module Operating Temperature (NMOT)	42±2 °C	Front glass	2.0mm tempered glass, low iron
Maximum System Voltage	1500V	Frame	Anodized/Electrophoretic aluminum alloy
Maximum Series Fuse	30A	Junction Box	IP68
Grounding conductivity	<0.1Ω	Output Cables	4.0 mm2
Safety Class	Class II	Hailstone Impact Test	80 km/h for 25mm ice ball
Insulation Resistance	≥100MΩ		

9. Diode Information

POWERBAY module connecting box contains bypass diode which is in parallel connection with the cell strands. If heat spot occurs locally with the module, the diode will come into operation to stop the main current from flowing through the heat spot cells with the view to restrain module heating and performance loss. But bypass diode is not the overcurrent protection device.

If the diode is found or doubted to get out of order, the installer or system maintenance supplier shall contact POWERBAY. Please do not try to open the module connecting box on your own.

Based on the maximum series fuse rating of module and local electrical installation code, always make sure POWERBAY PV modules are assembled with the appropriate string fuse for circuit protection. Usually POWERBAY PV modules' maximum series fuse rating is 30A. Type: 1.35SQ045/2.PV3045TS

For Australia Market, Building integrated PV Module installations must comply with the requirements of the National Construction Code and AS/NZS 5033.

10. Release and execution

This manual is subject to centralized management of the POWERBAY technical platform, and the final execution and interpretation of this manual shall be the responsibility of the technical platform.

POWERBAY Solar Panel User Manual & Installation Guide

Version Number – 003

Power Bay Pty Ltd

Phone: 1800 95 95 09

Website: www.powerbay.com.au

Email: service@powerbay.com.au

